

## Revision History

Rev	Description	Date	Approved
E	Update OEM Part No.	17/12/24	JB

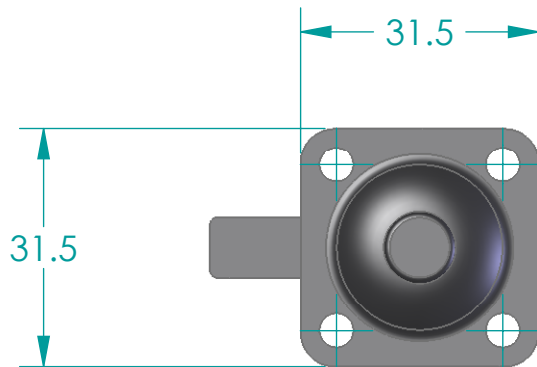
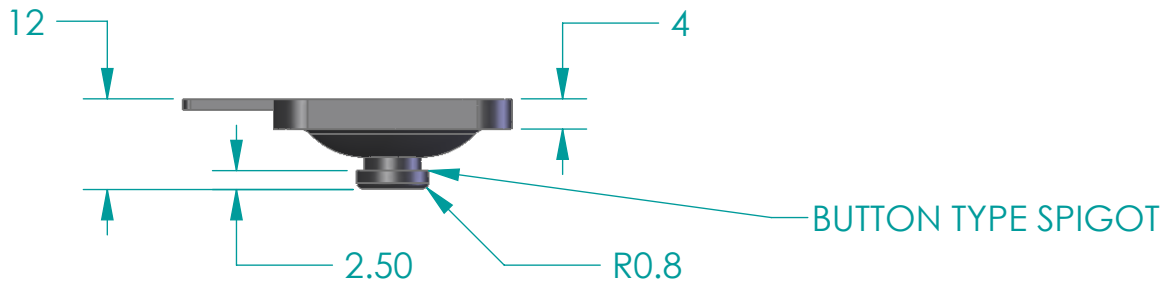
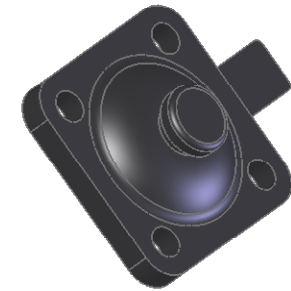
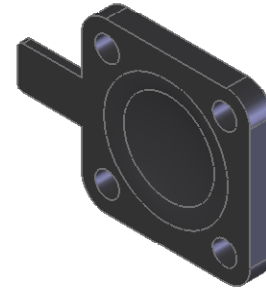
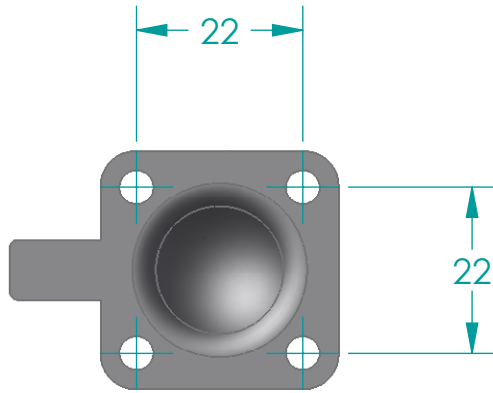

### Replacement Diaphragm for:-

OEM PART = 600 8M17

USED ON 1/2" (DN8) Diaphragm Valve

	Name	Date	 <b>DIAPHRAGM DIRECT</b>
Drawn	M.Mc Keon	17/12/24	
Checked			
<b>Material - EPDM</b> Complies with CFR 177.2600 and Conforms to USP Class VI Biological Reactivity Tests Section #87 and #88			TITLE <b>DD03-GE7</b>
Size A	FOOT PRINT DIMENSIONS		Rev E
File Name: DD03-GE7-RevE			
SCALE: 1:1			Sheet 1 of 1

Disclaimer - Diaphragm Direct® does not manufacture, represent, nor sell OEM valves or diaphragms manufactured by any other company. Diaphragm Direct® brand diaphragms are not sponsored by any other manufacturers. Any name, model, part number, brand, image, material or referral is for descriptive purposes only. Diaphragm Direct® brand replacement diaphragms are guaranteed to fit OEM equipment and meet or exceed OEM specifications. Diaphragm Direct® brand replacement diaphragms are covered by the standard Diaphragm Direct® limited product warranty.